



dZ]• š •Z š % Œš ]v• š} šZ  
 U u š] μo}μ•oÇ •]Pv (}Œ %o%o] š}}v ]v šZ š o }uu  
 • š}Œ•X /š (- ]Œššš]}v d šŒ vîžŒ}•]šŒ}((] % Œ o U ô }uu}  
 o v • }( ííí' W DŒX dZ o Z Œ •Kš}&WZ^&ZŒ^Œ}ŒŒ ](š}Œ v  
 }u%o] • Œ]P}Œ}μ•Œ}Œ}šZP ŒμoŒš]vš ~D^ • •%o ](] š}}v•X

^μ%o%}ŒŒ P	s	-ìXì	ìXò	
š /v%oμš s}oš P	s	-ìXì	ìXò	
}všŒŒ}μš s}oš P	s	-ìXì	ìXò	
K%o Œ š]vP d u%o Œ šμŒ	£	ì	óì	
^š}Œ P d u%o Œ šμŒ	£	-òì	=ôñ	
Z o š]À ,μu]-]šŒ Œ}vP•	9	ñ	ôñ	

^μ%o%oÇ s}oš P ~s •	s	ìXííñ	ìXì	ìXò	W Œ
W}Á Œ }v•μu%oš}}v	t			íXñ	W Œ
K%o Œ š]vP • d u%o Œ	£	ì		óì	
K%o Œ š]vP Z o š]À ,μu]	9	ì		ôñ	
D} μo š}}v &}Œu š		ííí' W -D			
]š Z š	' %o•	ôŒì' š}žŒŒííí'			

Z Œ š Œ}μš] v	}Zu	òì	ííí	ííí	
d]uWŒ}%o P š}}v o Ç ~/ v•	YXX	YXX	ŒXó		

í	/> /v• Œš}}v o}•• š îòXí	í õ X ó ñ ~D	/ ô î X î   ^ š}}ò î X í X í
î	/> /v• Œš}}v î ò X ñ ò š, î	í í ~D]v X	/ ô î X î   ^ š}}ò î X í X í
ï	Z> D]v]uµu o •• u o Ç	E ô X í ñ Ž X	/ ô î X î   ^ š}}ò î X í X í
ð	Z> ](( Œ -uš] oš} }uu}vu} Œ š µ Œ v o}••	ì X í í', ð ð', ð <µ š}}v ð ð ð	/ ô î X î   ^ í ò î X í X ð
ñ	/> ](( Œ -uš] oš} }uu}vu} ]v• Œš}}v o	ì X í í', ð ð', ð <µ š}}v ð ð ð	/ ô î X î   ^ í ò î X í X ñ
ò	Z> }uu}vu} š} }uu}y Œ š µ Œ v o}••	ì X í í', ð ð', ð <µ š}}v ð ð ð	/ ô î X î   ^ š}}ò î X í X ò
ó	K D	ï ~D]v X•	/ ô î X î   ^ š}}ò î X í X ó
Ž o •• u o ] • Á]šZ }u P Œ š Œ š Z v ð Œ v }š Œ			

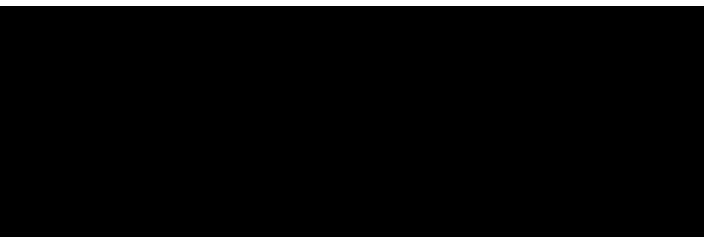

W]	>}P]	^Çu }o	• Œ]‰š]}v	W o μ P ^ < μ v	E }š
í		'E	'Œ}μv	í	
î	D>/	dyî‰	dŒ v•u]šš Œ-/vÀ Œšv	ï	

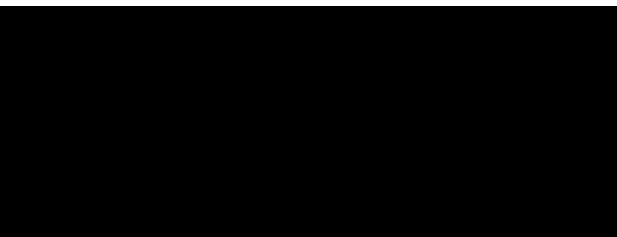

íí	D>/	dyô‰	dŒ v•u]šš Œ/vÀ Œš	ï	
íî	D>/	dyôv	dŒ v•u]šš Œ š /vÀ Œš	ï	
íï		'E	'Œ}µv	í	
íð	>s DK/K	^ >	î-Á]Œ ^ Œ] o ]vš Œ( o	ï	í
íñ		s	=ïXïš W}Á Œ	î	
íò		s	=ïXïš W}Á Œ	î	
ío	Dµøš]À o	>WtvIWZ	>}ÁW}Á Œ D} l D} µo WŒ	ï	î
íô		'E	'Œ}µv	í	
íõ	D>K	Zyóv	Z ]À Œ š /vÀ Œš	ï	
íî	D>K	Zyó‰	Z ]À Œ -š/vÀ Œš	ï	

ñ í		'E	'Œ}µv	í	
ñ î	D>/	dyñv	dŒ v•u]šš Œ š /vÀ Œš	ï	
ñ ï	D>/	dyñ%	dŒ v•u]šš Œš /vÀ Œš	ï	
ñ ð		'E	'Œ}µv	í	
ñ ñ	D>/	dyiv	dŒ v•u]šš Œ š /vÀ Œš	ï	
ñ ò	D>/	dyi%	dŒ v•u]šš Œ- /vÀ Œšv	ï	
ñ ó		'E	'Œ}µv	í	
ñ ô	D>/	dyiv	dŒ v•u]šš Œ š /vÀ Œš	ï	
ñ õ	D>/	dyi%	dŒ v•u]šš Œ- /vÀ Œšv	ï	
ò ì		'E	'Œ}µv	í	
E}š íW					
K%o- vŒ ]v Á]šz%o(Œo•)•š}Œ }v ,}•šX					
E}š îW					
^ %o]v • Œ]%oš}}v (}Œ Œ (µ]Œ ]Œ µ]š					



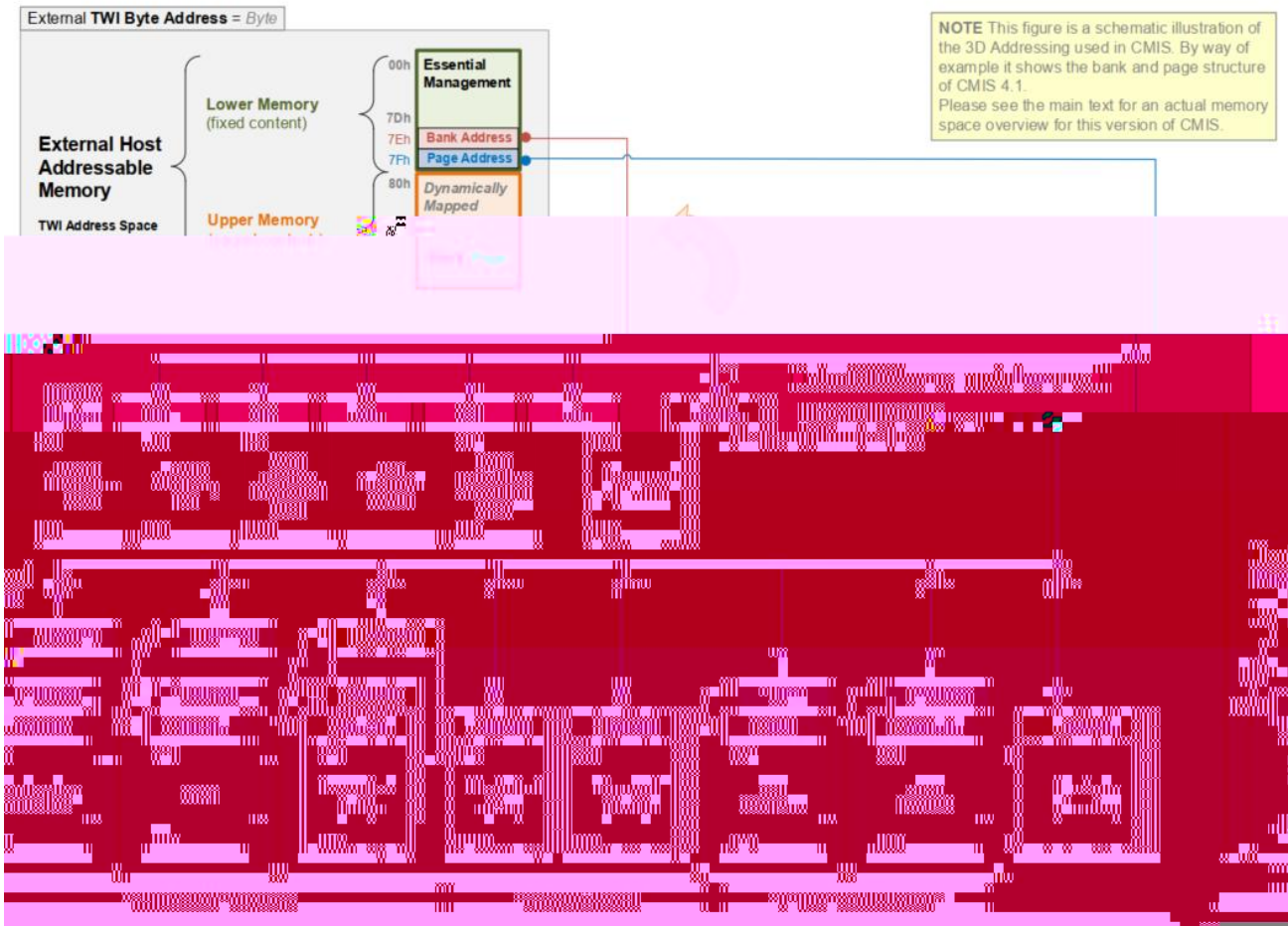

■ > } Á Œ D u } Œ Ç K À Œ À } Á

0-3	4	ID and Status Area	Module ID from SFF-8024 list, version number, Type and status Flat mem indication, CLEI present indicator, Maximum TWI speed, Current state of Module, Current state of the Interrupt signal
4-7	4	Lane Flag Summary	Flag summary of all lane flags on pages 10h-1Fh
8-13	6	Module-Level Flags	All flags that are not lane or data path specific
14-25	12	Module-Level Monitors	Monitors that are not lane or data path specific
26-3	5	Module Global Controls	Controls applicable to the module as a whole
31-36	6	Module-Level Flag Masks	Masking bits for the Module-Level flags
37-38	2	CDB Status Area	Status of most recent CDB command
39-40	2	Module Firmware Version	Module Firmware Version
41-63	23	Reserved Area	Reserved for future standardization



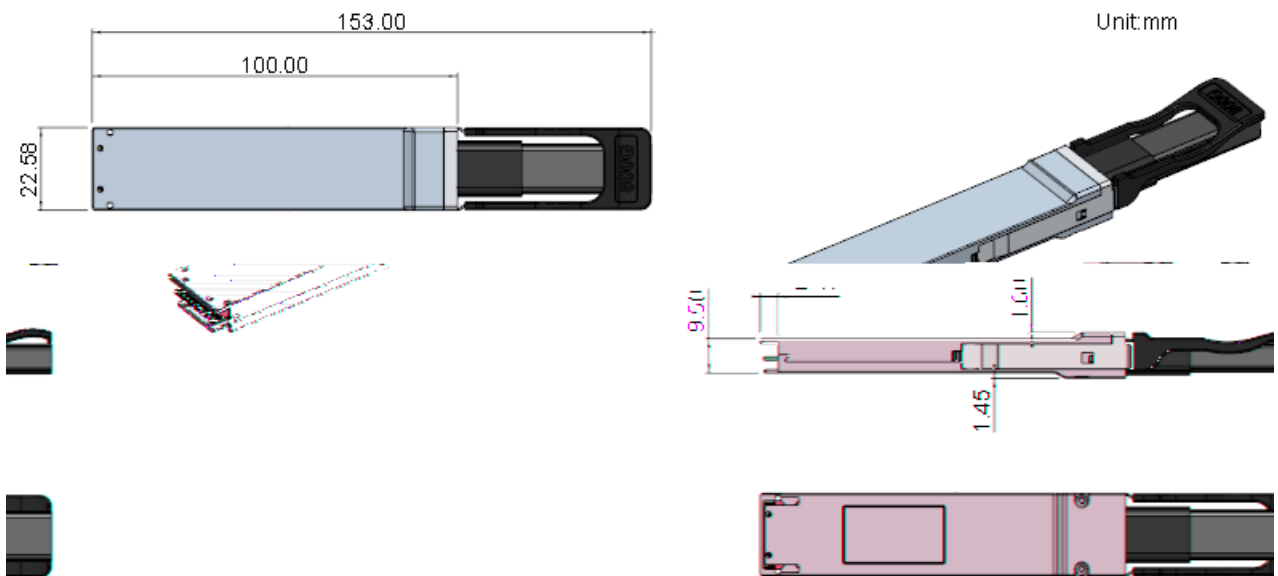
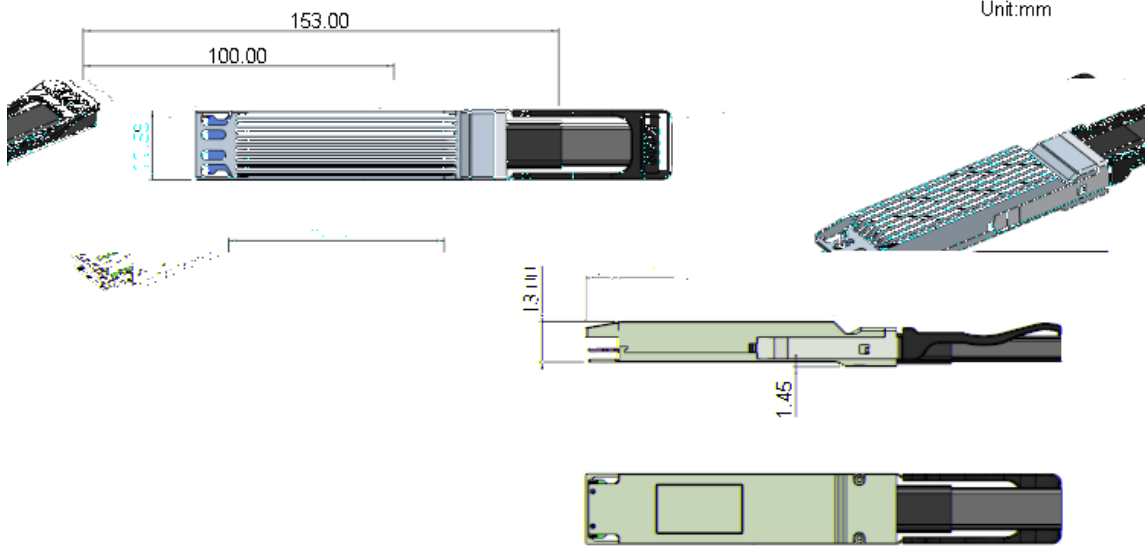

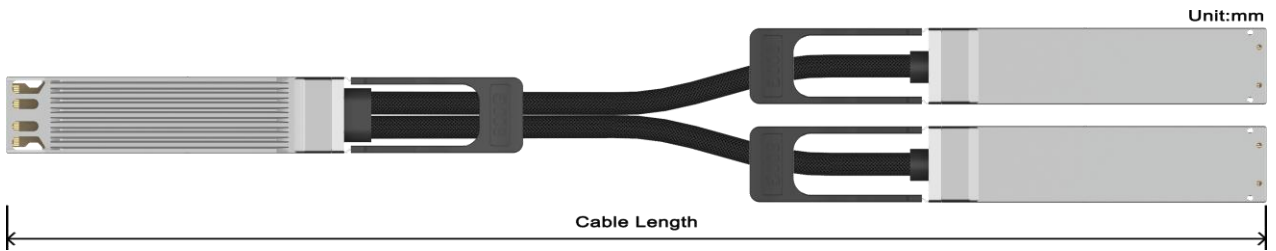

K^&W-îžK^&W ðii' -iiñ	K^&W ôii' š} îž K^&Wðii' ~ðž šš Z μ o U X ñ D'	Fii	ii
K^&W-îžK^&W ðii' -iii	K^&W ôii' š} îž K^&Wðii' ~ðž šš Z μ o U Xi Dt'	Fii	ii
K^&W-îžK^&W ðii' -îôii	K^&W ôii' š} îž K^&Wðii' ~ðž šš Z μ o U Xi ð Dt'	Fii	îô
K^&W-îžK^&W ðii' -îôiiñ	K^&W ôii' š} îž K^&Wðii' ~ðž šš Z μ o U Xi ð Dt'	Fði	îô
K^&W-îžK^&W ðii' -îôii	K^&W ôii' š} îž K^&Wðii' ~ðž šš Z μ o U Xi ð Dt'	Fði	îò

dZ %o OE({OEu v (]PμOE •U š U v vÇ ]ooμ•šOE š]À u š OE] o  
v uμ•š AE%o o] ]šoAE]š]v]E uÇ ]v K>KE' (}OE šZ Ç OE u  
vÇ •%o ](] }OE OE }OE }všOE šX

Ç •, K>KE' -• %o}o] Ç }( }vš]vμ}μ• ]u%o OE}À u všU •%o ](] š}}v•  
dZ %oμ o] š}}v }( ]v({OEu š}}v ]v šZ]• š •Z š } • v}š ]u%o oÇ  
%o OE}š š]À OE]PZš• Z o Ç •, K>KE' }OE }šZ OE %o OEš] •X ]š}}  
•, K>KE' • o • OE %o OE • vš š]À X

ìí	/v]š] o Z o •	: u • Z v	ìíííòííííð
îî	D} ](Ç Wœ} μ š >]•š		