

-
-
-
-
-
-
-

-
-
-
-
-
-
-

-
-
-
-
-
-
-
-
-



| | | | | |
|--|--|--|--|--|
| | | | | |
| | | | | |
| | | | | |
| | | | | |
| | | | | |
| | | | | |
| | | | | |

| | | | | | |
|--|--|--|--|--|--|
| | | | | | |
| | | | | | |
| | | | | | |
| | | | | | |
| | | | | | |
| | | | | | |
| | | | | | |

| | | | | | |
|--|--|--|--|--|--|
| | | | | | |
| | | | | | |
| | | | | | |



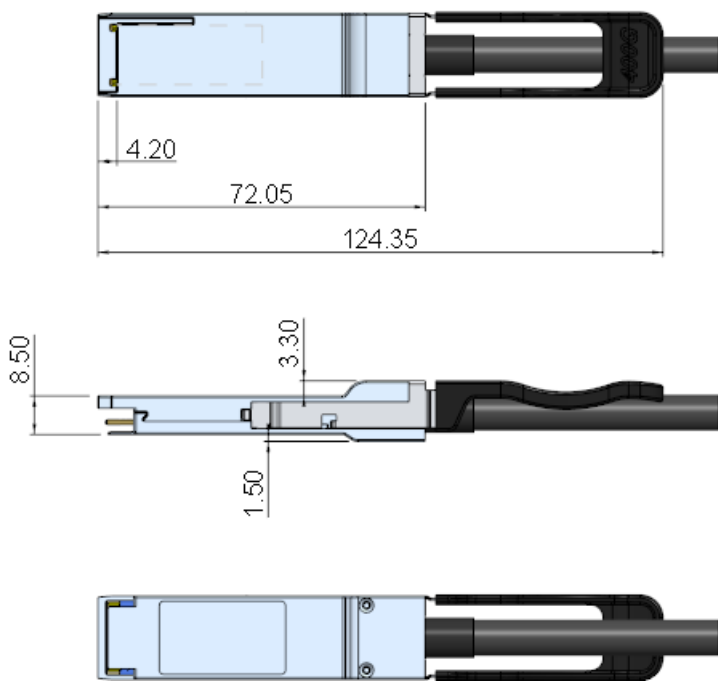

Unit:mm

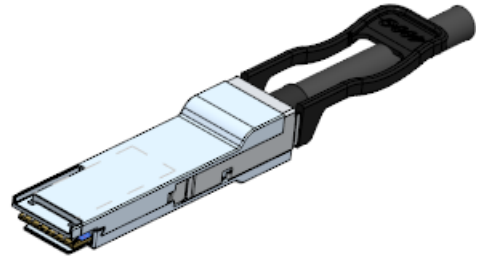



| | | | |
|--|--|--|--|
| | | | |
|--|--|--|--|



| | | | |
|--|--|--|--|
| | | | |
|--|--|--|--|