





--	--	--	--	--	--

	B		T T
	B		T T
	B T		T T
	Bt T		T T
	Bt T		T T
	BTT T		T T
			T T
	T		B

Top PCB viewed from top

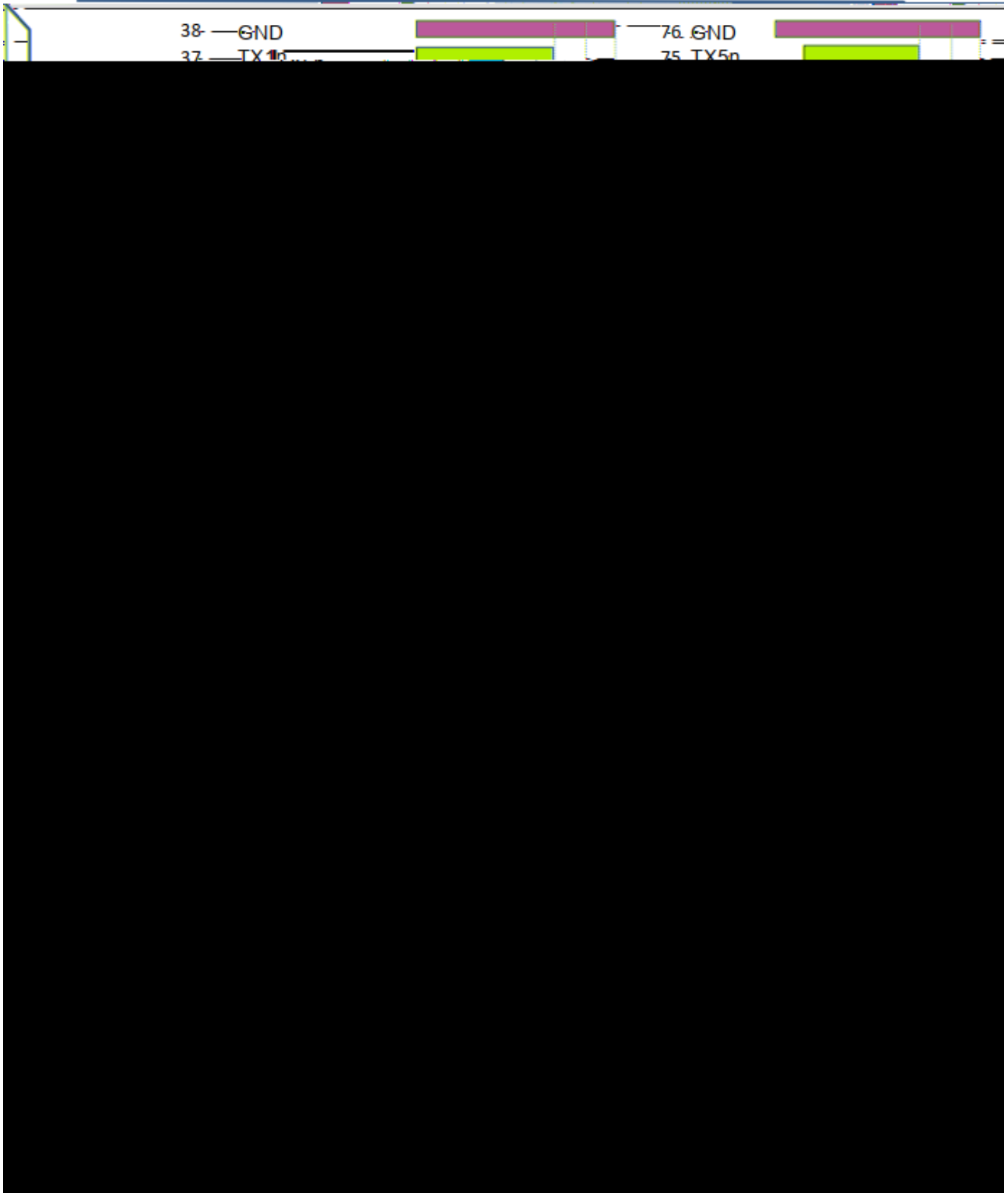



		D			
	B				
	B		D		
		D			
	B				
	B		D		
		D			
	B B		B		
	B B		B		
		TT	T		
	B	B	T T T		
	B em-US		T T T		

	B		T		
	B		T D		
		D			
	B		T		
	B		T D		
		D			
	B B	B			
	B B	B	B		
		TT			
		TT			
	B B	B	B		
		D			
	B		D		
	B				
		D			
	B		D		
	B				
		D			
		D			
	B				
	B		D		
		D			
	B				
	B		D		
		D			
	B B		TT		
	B B		TT		
		TT			
	B B		TT		
	B B		TT		
		D			
	B		T D		
	B		T		
		D			
	B		T D		
	B		T		
		D			
		D			
	B		T		

	B		T D		
		D			
	B		T		
	B		T D		
		D			
		D	D T		
		TT			
		TT			
	B	T	T T T T T		
		D			
	B		D		
	B				
		D			
	B		D		
	B				
		D			

D  
H ηρÉί μ

D					
		T	T		T
	T				

		D			
	B				
	B		D		
		D			
	B				
	B		D		

	B B	B			
		TT	T		
	B	B	TTT		
	B		TTT		
		D			
	B		T D		
	B		T		
		D			
	B		T D		
	B		T		
		D			
		D			
	B		T		
	B		T D		
	B				
	B				



	B		D		
	B				





			T T
		T	D T T
		T	T
		T	
		T	T

Unit:mm

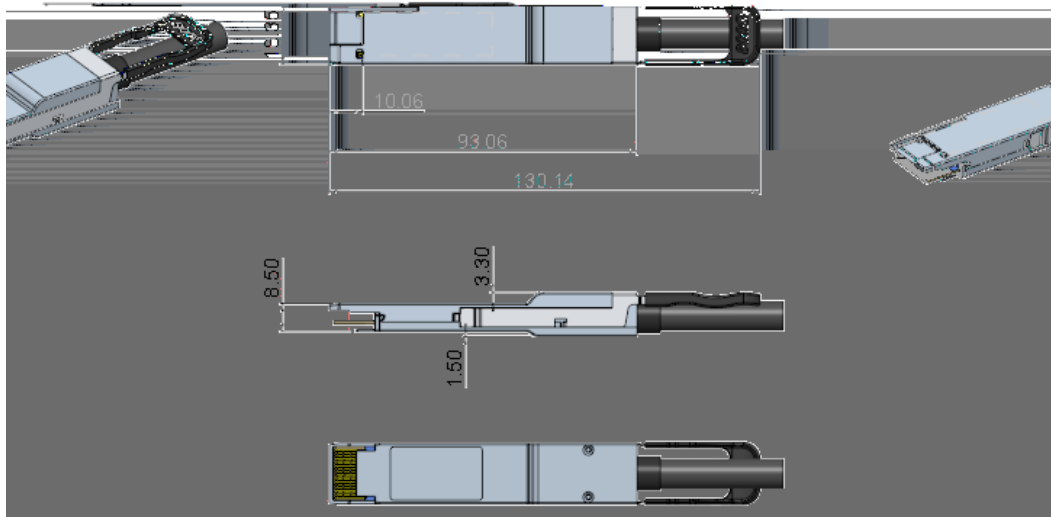

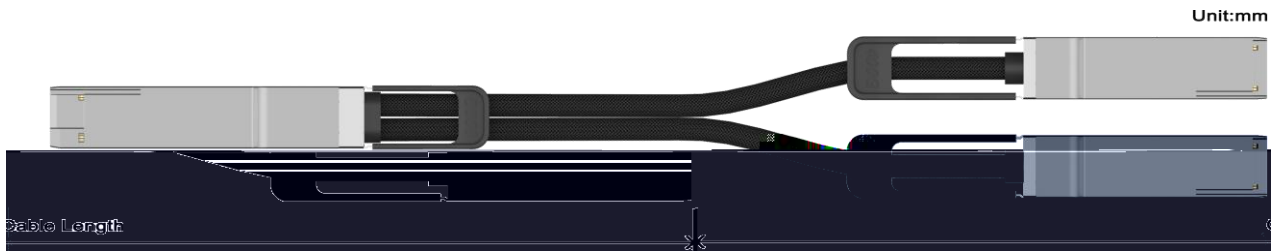

H	H	H	H	T	
H	H	H	H	T	
H	H	H	H	T	
H	H	H	H	T	
H	H	H	H	T	
H	H	H	H	T	
H	H	H	H	T	
H	H	H	H	T	
H	H	H	H	T	

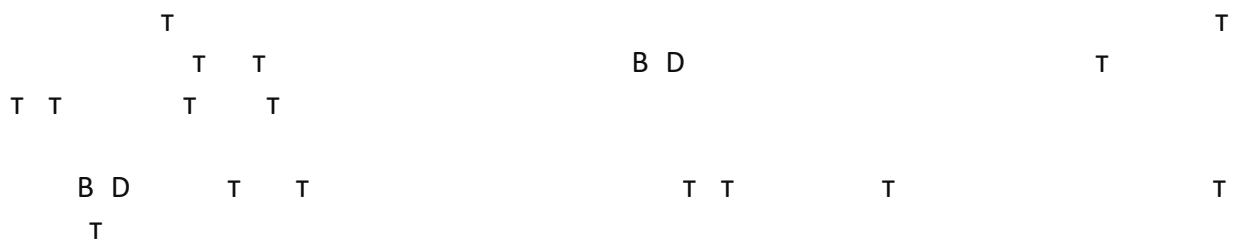

T  
B D

B D

T