

-
-
-
-
-
-
-

-
-
-
-
-
-
-

-
-
-
-
-
-
-
-
-
-





Top PCB viewed from top

38 - GND
37 - TX10



76.GND
75.TX5p

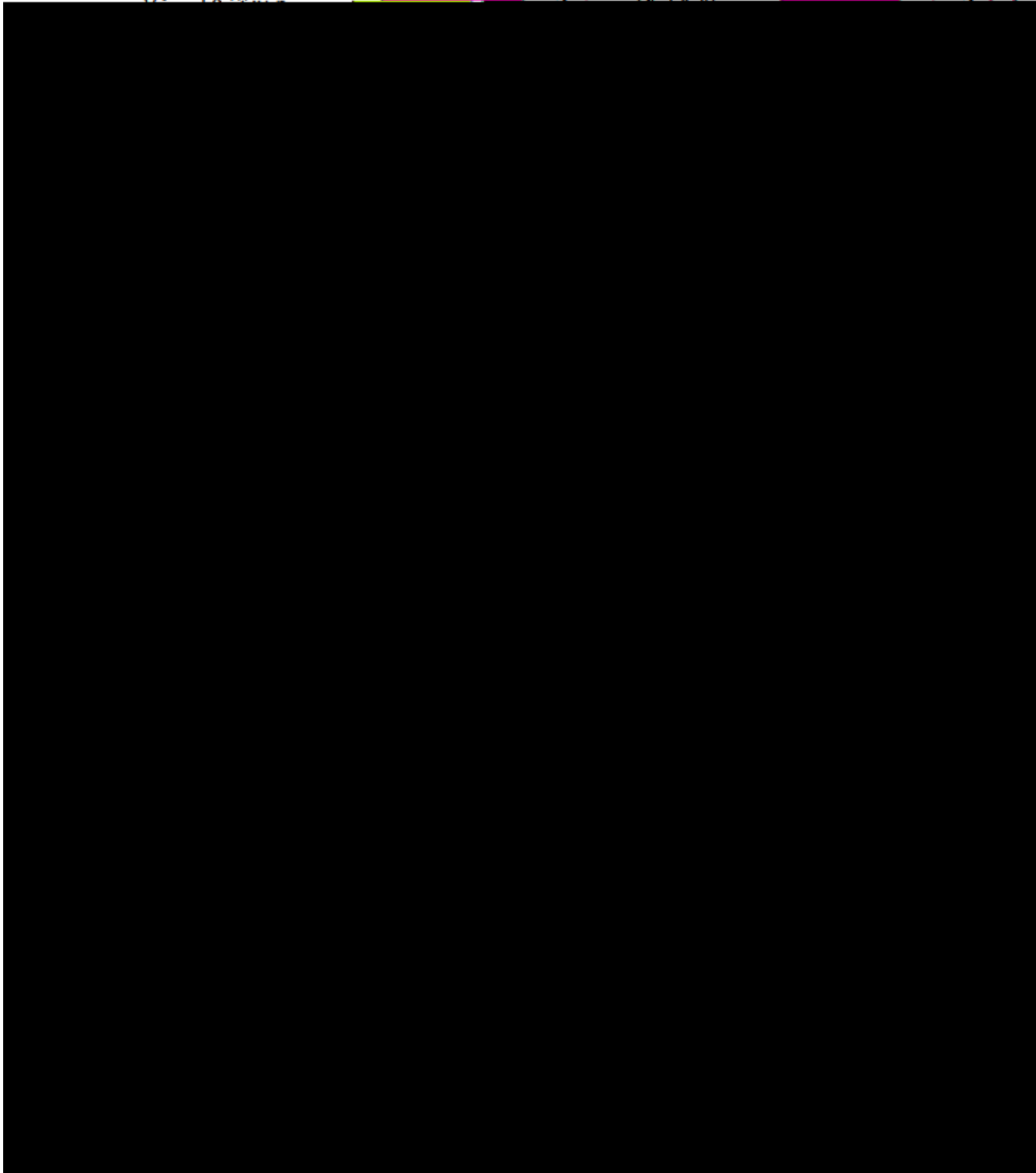



WIRING TABLE

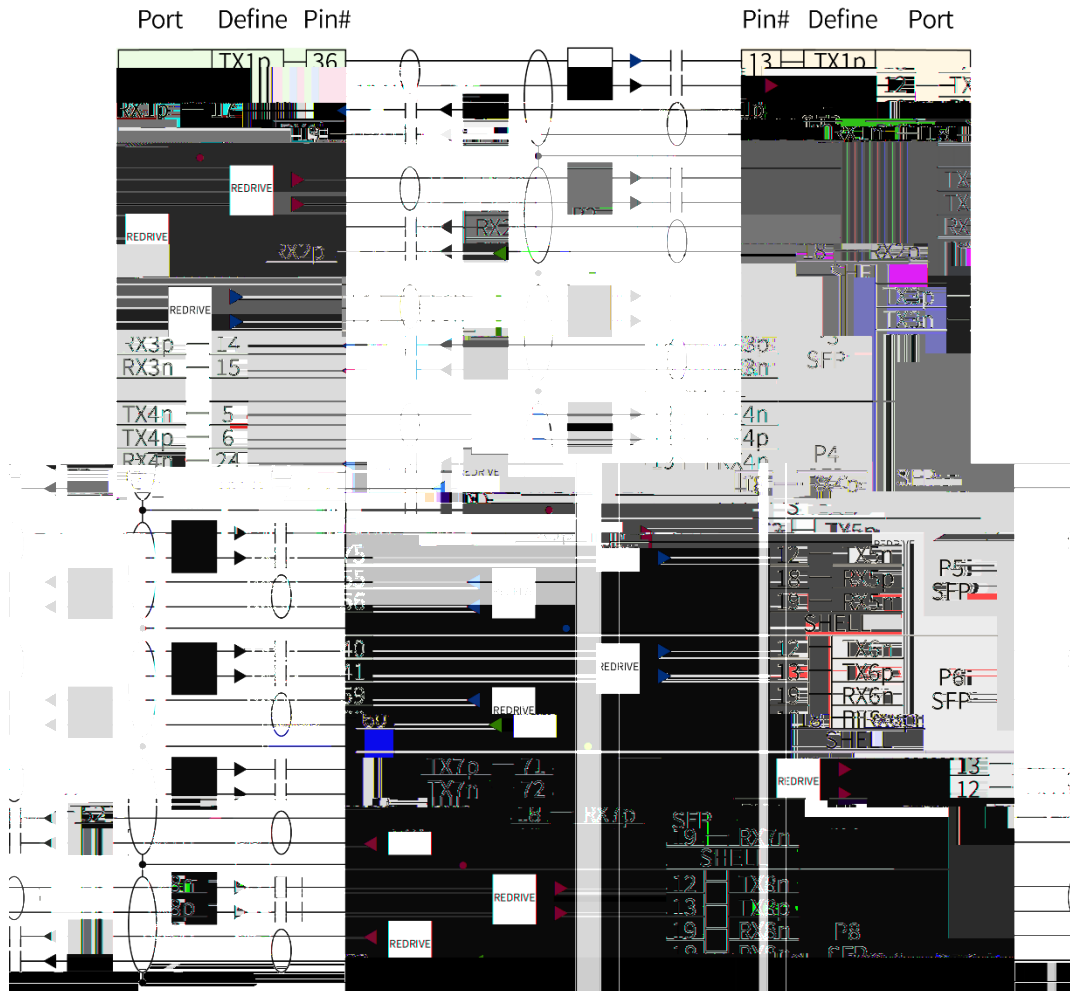

Unit:mm

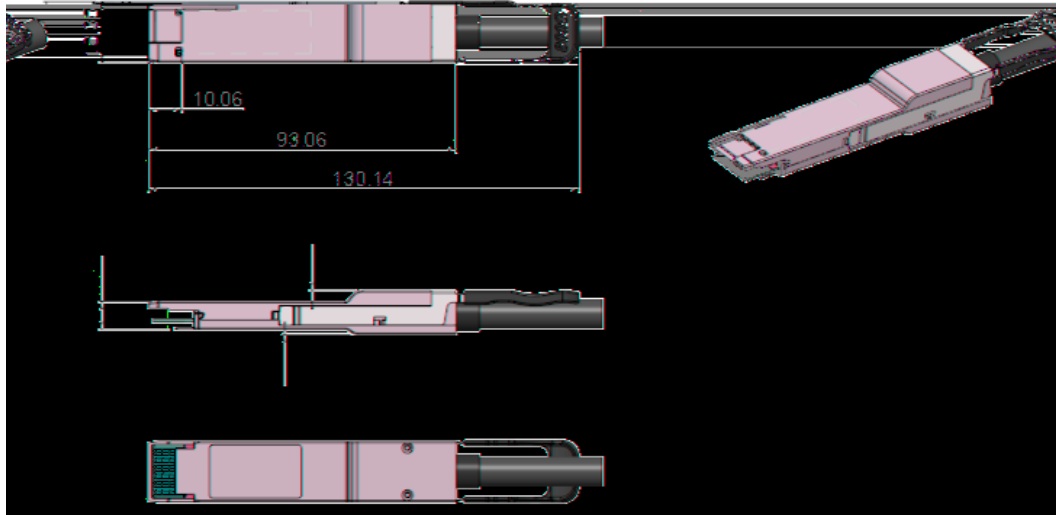

Unit:mm

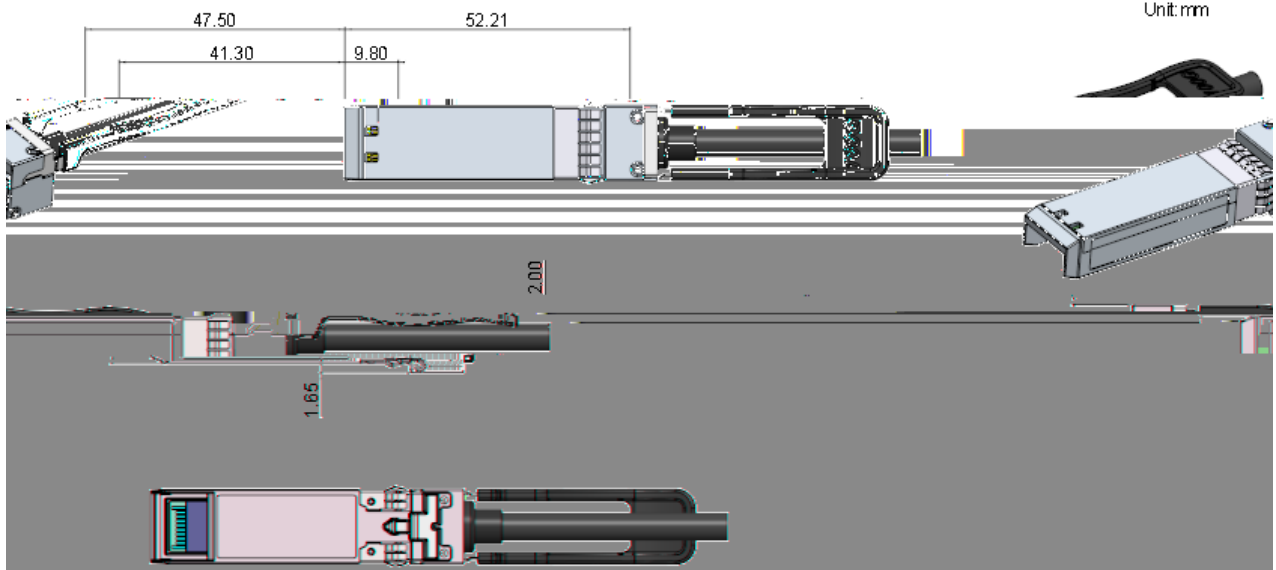

--	--	--	--

